



P818 Series

MECHANICAL SEALS

DESCRIPTION

The P818 series is a robust single cartridge seal for slurry application intended to provide an excellent sealing performance for pumps. As one of the member of RST Mechanical Seals, P818 is designed to operate in a wide range of process fluids. P818 particularly exhibits high performance in the operation of critical process fluids of hydrocarbon, boiler feed water, sour gas, propane and butane, non-flashing hydrocarbon and flashing hydrocarbon. The improvements in design reliability and robustness are made possible by the utilisation of sophisticated Finite Element Analysis (FEA) Engineering Software. These features are further verified by the usage of ProEight's high-end testing equipment, the patented mechanical seal static tester – AccuTEST[®] and mechanical seal dynamic tester – AccuDYN[®] (Patent Pending).

The adoption of modularity concept has made P818 series even more versatile. Coupled with added interchangeable feature, P818 series seals are able to fit in various conditions, wider range of operating pressures, temperatures and process fluids. This concept ensures that the P818 series seal requires only minimum change-out on its seal face to suit these conditions, eliminating the need to redesign a completely different mechanical seal configuration. To cope with temperature sensitive environment, Low-temperature Inducing Face, ARCAF[®] is designed for this particular need. ARCAF[®] can be interchanged with other RST Standard Faces to suit other different operating conditions.



INDUSTRIAL APPLICATION

- Oil & Gas Production
- Petroleum Refining
- Pipeline
- Pulp & Paper

SEAL APPLICATION

- ANSI B73.1M and DIN 24960 Pump-Compliant
- Centrifugal Heavy Duty Pumps
- Centrifugal API Process Pumps
- Centrifugal General Purpose Pumps
- Positive Displacement Pumps

DESIGN OVERVIEW

- Meet API682 technical design configurations and requirements
- Materials Selection and Design is in accordance with API682 Standard
- RST Design Optimization for seal face design
- Flushing Flow pattern is optimised around seal faces, removing trapped vapour
- High efficiency buffer circulation system

RST DESIGN PHILOSOPHY

Advanced FEA Program for Design Optimization

ProEight in-house FEA programs, SIGMA-FEA and CELC-FEA combined with ANSYS were used extensively to design the RST mechanical seals. Steady state and transient conditions coupled with various possible sealing environment gave a clear overview on the mechanical seal's performance. These software programs analyse combined seal distortion due to pressure, temperature, stress distortion and face loadings.

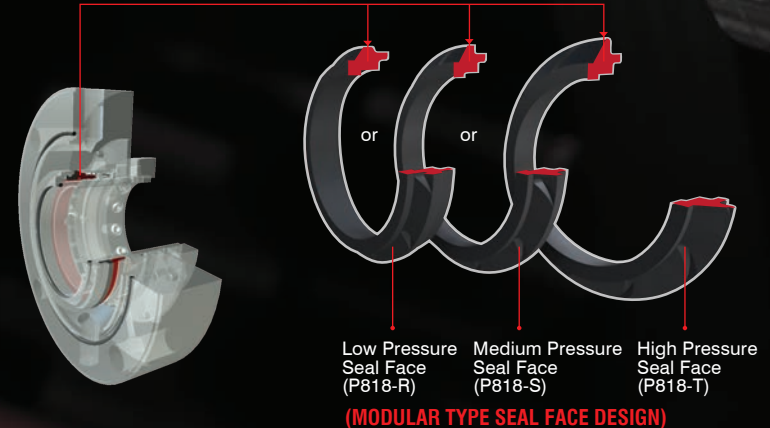

Internal Compression Unit

The main component of the seal is interchangeable to suit wide range of seal application.

PERFORMANCE CAPABILITIES

Temperature : -30°C to 205°C / -20°F to 400°F

Pressures : Up to 21 bar g/300 psig

Speeds : Up to 25 m/s / 5,000 fpm

SEAL PARTS

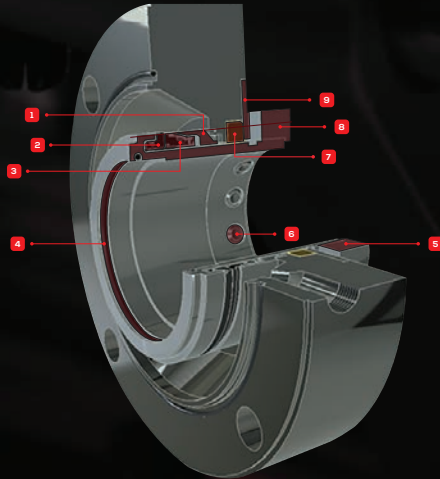

- 1** Spring Holder
- 2** Seat
- 3** Seal Face
- 4** O-Ring
- 5** Drive Collar
- 6** Set Screw
- 7** Throttle Bushing
- 8** Shaft Sleeve
- 9** Bushing Retainer

MATERIAL SPECIFICATION

SEAL COMPONENTS		MATERIALS	
Description		Standard	Custom
Seal Face		Resin Impregnated Carbon	Tungsten Carbide (WC) Alpha Sintered Silicon Carbide (α -SiC) Antimony Impregnated Carbon Reaction Bonded Silicon Carbide (RbSiC)
Seat		Reaction Bonded Silicon Carbide (RbSiC)	Alpha Sintered Silicon Carbide (α -SiC)
Drive Collar Thrust Ring Set Screw Shaft Sleeve	Throttle Bushing Flange Bushing Retainer	Stainless Steel 316L (UNS S31603) Stainless Steel 304L (UNS S30403)	Duplex (UNS S31803) Hastelloy [®] C-276 (UNS N10276) Bronze Titanium Alloy (UNS R56401)
Spring		Stainless Steel 316L (UNS S31603)	Hastelloy [®] C-276 (UNS N10276) Stainless Steel 304L (UNS S30403)
O-Ring		Fluoroelastomers - Viton [®] (FKM)	Amine-Resistant Perfluoroelastomer (FFKM) Low Temp Nitrile Butyl Rubber (NBR) Teflon Encapsulated Viton (VMQ) Ethylene Propylene Diene Monomer (EPDM)

DESIGN FEATURES

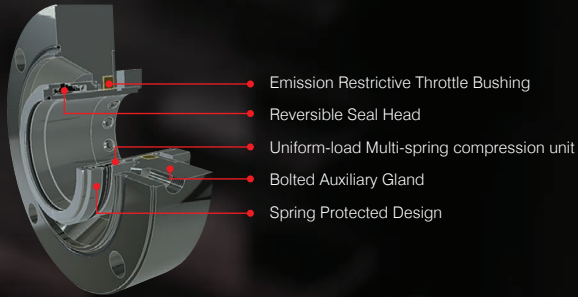

DESIGN DRAWING

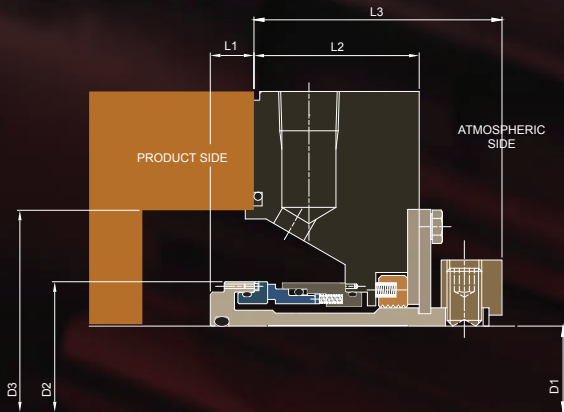

PERFORMANCE CURVE

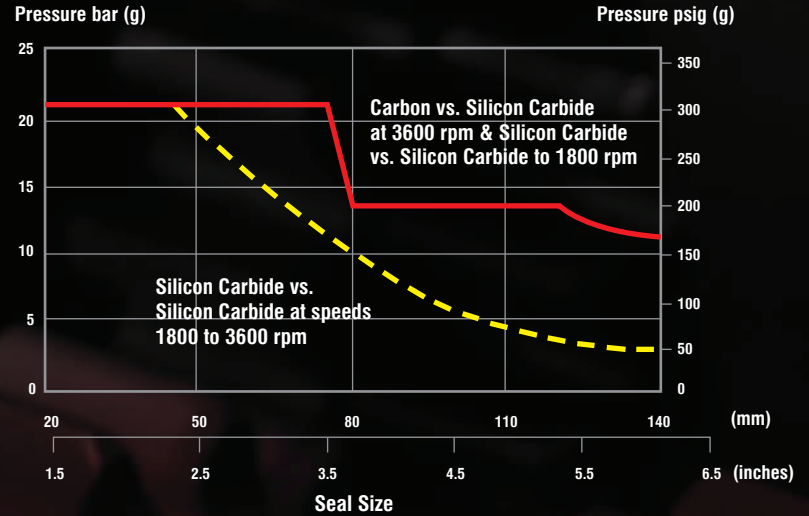

- Carbon vs. Silicon Carbide at 3600 rpm & Silicon Carbide vs. Silicon Carbide to 1800 rpm
- Silicon Carbide vs. Silicon Carbide at speeds 1800 to 3600 rpm

DIMENSIONAL DATA

Seal Size *	D1	D2	D3	L1	L2	L3
0254	25.40	39.73	41.28	15.77	34.37	49.63
0285	28.58	42.90	44.45	14.96	36.73	52.37
0317	31.75	46.02	47.63	16.92	36.73	52.37
0349	34.93	49.25	50.80	16.92	36.73	52.37
0381	38.10	55.55	57.15	15.72	37.77	53.98
0412	41.28	58.72	60.33	15.72	37.77	53.98
0444	44.45	61.11	62.99	15.72	37.77	53.98
0476	47.63	64.74	66.68	15.72	37.77	53.98
0508	50.80	67.89	69.85	16.51	40.67	58.72
0539	53.98	71.07	73.03	16.51	40.67	58.75
0571	57.15	74.24	76.20	16.51	40.67	58.75
0603	60.33	77.42	79.38	15.16	43.61	62.64
0635	63.50	83.85	85.73	10.59	43.61	65.10
0666	66.68	90.20	92.08	14.94	41.28	63.50
0698	69.85	90.20	92.08	14.94	41.28	63.50
0730	73.03	91.80	93.65	14.94	43.82	63.50
0762	76.20	98.15	99.92	13.36	45.39	65.07
0793	79.38	102.16	104.78	15.09	40.46	65.07
0825	82.55	102.16	104.78	14.81	40.46	63.75
0857	85.73	107.85	111.13	15.09	40.46	65.07
0889	88.90	111.02	114.30	15.09	40.46	65.07
0920	92.08	114.30	117.48	15.09	40.46	65.07
0952	95.25	117.48	119.99	15.09	40.46	65.07
0984	98.43	120.65	123.83	15.09	40.46	65.07
1016	101.60	123.83	127.00	15.09	40.46	65.07
1047	104.78	127.00	130.18	15.09	40.46	65.07
1079	107.95	130.18	133.35	15.09	40.46	65.07
1143	114.30	136.53	139.70	15.09	40.46	65.07
1206	120.65	142.88	146.05	15.09	40.46	65.07
1270	127.00	155.58	158.75	14.38	44.42	77.29
1333	133.35	161.93	165.10	14.38	44.42	77.29
1397	139.70	168.28	171.45	14.38	44.42	77.29

* All dimensions are in mm

D1 assumes a standard ISO tolerance for shaft (ISO286-2)

Fluid Type	Temperature Range		Weightage
	Min (°C)	Max (°C)	
Lubricating Fluid Light Hydrocarbon	60	80	1.00
	81	100	0.96
	101	120	0.90
	121	160	0.84
	161	180	0.80
	181	200	0.65
	201	220	0.62
Aqueous Solution	40	100	0.75

For further information, please consult our Technical Support Engineer.

NOTES:

1. The pressure weightages only confirm to seals with carbon primary rings. Hard face vs hard face combination seals are not applicable.
2. The listed temperatures are referred to single seal's product temperatures. For dual seals, the listed temperature are referred to the product fluids & buffer/barrier fluid's average temperature.

EXAMPLE FOR DETERMINING PRESSURE RATING LIMITS:

Seal : 50.8mm/2.000" diameter Type P818
 Product : Lube Oil
 Temperature : 82 °C/180 °F
 Speed : 3200 rpm

Using P818 performance curve, the pressure limit is 20 bar g/290.1 psig. From the table above, apply the weightage value, in case 0.96. For this service condition, the maximum operating pressure is: 20 bar g/290.1 psig x 0.96 = 19.2 bar g/278.50 psig.

All specifications are based on extensive tests and our many years of experience. The diversity of possible applications means, however, can only served as guide values. We must be notified of the exact conditions of application before we can provide any guarantee for a specific case. Subject prior to change.